

BALL TRAINER

DUAL-FUNCTION LAUNCHER / DROPPER

Owner's Manual

Please read this manual thoroughly
before operating the Dogtra BALL TRAINER.

IMPORTANT SAFETY AND PRODUCT INFORMATION

WARNING

Please read all safety and product information below before using your Dogtra product. Failure to follow these safety instructions could result in injury to you, your dog and others, or it could result in damage to your Dogtra product or other property.

PRODUCT SAFETY

Proper Use

Your Dogtra product should be used only to train and educate your dog. Always supervise your dog when using your product. Only operate your product when you and your dog are at a safe distance from the product. Never operate your Dogtra product when you or your dog could be struck by balls launched or dropped from the product.

Training Methods

Dogtra products may be used with a variety of training methods. However, each dog may have a different reaction to training methods and to Dogtra products. Closely observe your dog when determining the right training method to use with your Dogtra product.

Ball Requirements

Use only Dogtra-authorized balls or balls with a similar texture and size (diameter of 2.6 inches or 6.6 cm) with your Dogtra product. Do not use hard balls, smaller balls, partially or fully deflated balls, balls with protrusions, holes or straps, non-balls, or other objects as this may cause serious injury to you or your dog.

Ball Installation

Take care when inserting or removing balls from your Dogtra product as your fingers or hand may get caught. Do not insert or remove balls when your dog is nearby as your dog may attempt to retrieve the ball at the same time and injure you. Never operate your product when inserting or removing balls from the launch or drop canisters as this may cause serious injury.

Choking Warning

Do not launch or drop balls from your Dogtra product directly into the mouth of your dog as this may cause your dog to choke. Do not allow your dog to chew on balls used with the product as this could also be a choking hazard.

Aggressive Dogs

Do not use Dogtra products with aggressive dogs as such dogs may react adversely and cause injury to people or other dogs. Seek the assistance of a dog-training specialist or veterinarian when dealing with aggressive dogs.

Children

Dogtra products are not toys. Adult supervision and close attention are necessary when Dogtra products are used by or near children.

PRODUCT DAMAGE

Product Damage and Repair

Your Dogtra product can be damaged or malfunction if dropped, used with unauthorized balls, or otherwise improperly handled. Do not use a damaged or malfunctioning product as it may cause injury or property damage. If your product is damaged or malfunctions, contact Dogtra to obtain service before using the product.

Electrical Product

Your Dogtra product contains electrical components and batteries. Do not use or keep your product near heat or flammable sources. Do not use or keep your product in or near rain or other water sources. Such use or storage may damage your product and/or cause fire, explosion, injury, or property damage.

Medical Device Interference

Dogtra products contain electrical and magnetic components that emit low level electromagnetic waves and radio frequencies. These electromagnetic waves or radio frequencies may interfere with pacemakers, defibrillators, or other medical devices. Consult your physician or medical device maker before using your medical device with a Dogtra product. If you think that your Dogtra product is interfering with your pacemaker, defibrillator, or other medical device, stop using the Dogtra product.

UNAUTHORIZED USE

Your Dogtra product should be used only in a humane manner to train and educate your dog. Dogtra products are not intended for use in any other manner nor are they intended for use with other animals or with humans.

BATTERY

Your Dogtra product contains batteries. Take care when removing and installing batteries as your fingers may get caught. Dispose of batteries as provided by your local regulations. Do not disassemble, crush, heat, or otherwise alter the battery as it may cause fire, injury or property damage.

CONTENTS

AT A GLANCE	5
MAIN FEATURES	5
OVERVIEW	6
UNDERSTANDING YOUR TRAINING SYSTEM	
1. INTRODUCTION	8
2. TURNING THE RECEIVER ON/OFF	8
3. LAUNCHER/DROPPER MODE SWITCH	8
4. BALL	9
5. USING THE LAUNCHER	9
6. USING THE DROPPER	10
7. RECEIVER LED INDICATOR LIGHT	11
8. REPLACING THE RECEIVER BATTERY	12
9. TRANSMITTER LED INDICATOR LIGHT	13
10. REPLACING THE TRANSMITTER BATTERY	14
11. USING THE BATTERY CORRECTLY	14
12. MAXIMIZING THE DISTANCE	15
13. CODE SETTING	16
14. ATTACHING THE BELT CLIP	17
GENERAL TRAINING TIPS	18
MAINTENANCE	18
FCC WARNING	18
TROUBLESHOOTING GUIDE	19
WARRANTY AND REPAIR INFORMATION	20

AT A GLANCE

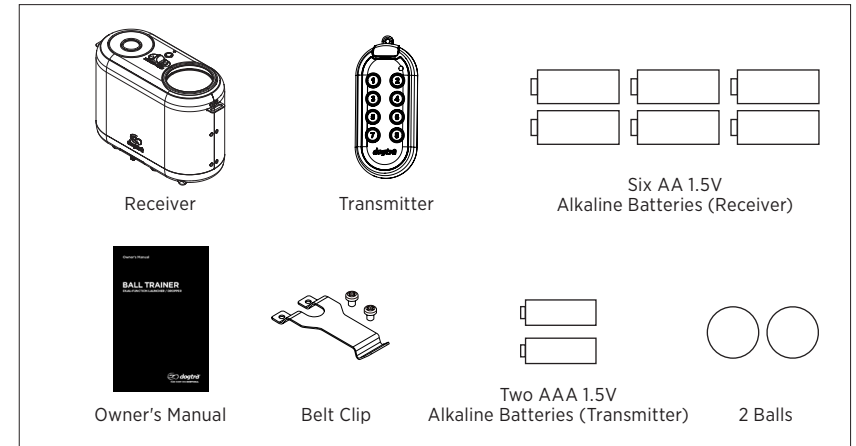

To purchase accessories, please visit www.dogtra.com or call customer service at 1-888-811-9111.

MAIN FEATURES

- Dual-function BALL TRAINER: Launcher and dropper
- Dropper can hold up to 3 balls
- Compact size with strap for versatile usage
- Expandable up to 8 BALL TRAINERS
- Launcher launches up to 5 feet
- 6 AA batteries for the BALL TRAINER receiver
- 2 AAA batteries for the BALL TRAINER transmitter
- 100-yard range
- LED indicator light to show the remaining battery life
- Launcher/Dropper Mode Switch on the BALL TRAINER receiver

OVERVIEW

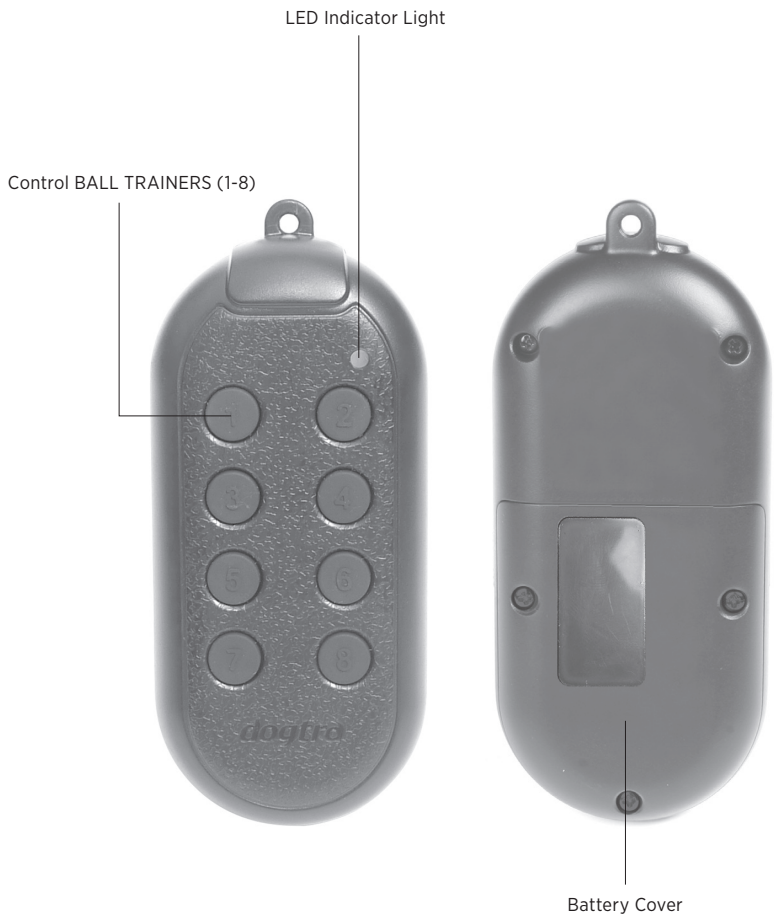

BALL TRAINER
Transmitter

OVERVIEW



BALL TRAINER
Receiver

UNDERSTANDING YOUR TRAINING SYSTEM

1. Introduction

The BALL TRAINER is a unique dual-function trainer that launches and drops balls, designed for training working dogs. The BALL TRAINER provides immediate rewards for trainings such as K-9 Scent Detection and Bark & Hold Training. The system has a 100 yard range and the launcher can shoot balls 5-feet high. A single transmitter can control up to eight receivers. The transmitter and receiver are equipped with replaceable batteries, which eliminates the need for recharging the system after each use. This system can be used at a training facility or at home.

2. Turning the Receiver On/Off



Turning the Receiver On:

Press and hold the on/off button on the top of the receiver until the receiver LED lights up solid green. The receiver will be ready to use when the LED is blinking every 5 seconds.

Turning the Receiver Off:

Press and hold the on/off button on the top of the receiver until the receiver LED lights up solid red. If the receiver is off, there will no longer be any blinking light.

Note 1: To extend the battery life, please turn the receiver off after use. If the receiver will not be used or kept in storage, please remove the battery completely.

Note 2: The BALL TRAINER receiver automatically turns off after 3 hours of non-use to conserve battery power.

3) Launcher/Dropper Mode Switch

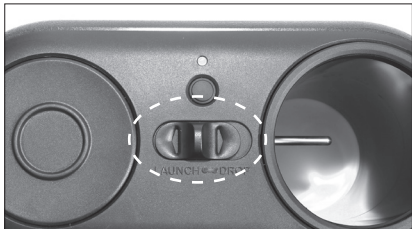

The Launcher/Dropper Mode Switch is located on the top of the receiver. Depending on which mode you would like to use, slide the switch to the launch mode or drop mode.

4. Ball



Balls You May Use:

2.6 inches or 6.6 cm diameter ball

Material: Rubber or cloth ball
(*No metal balls allowed, for example: golf balls)

Caution!

Do not launch or drop balls directly into the mouth of your dog as this may cause your dog to choke. Do not allow your dog to chew on balls used as this could also be a choking hazard.

5. Using the Launcher



1. Put the Launcher/Dropper Mode Switch in the launch mode.



2. Place the ball on the launcher portion.



3. Press the ball until it has loaded (you will hear a clicking sound).



4. The ball can only be launched once. If you would like to relaunch the ball, you will need to place it into the launcher again.

Caution!

Take care when inserting balls into the launch or drop canisters as your fingers may get caught or injured.

6. Using the Dropper



1. You can load more balls by extending the dropper.



2. You can load up to 3 balls in the dropper.



3. Put the Launcher/Dropper Mode Switch in the drop mode.

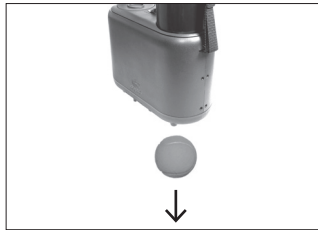

4. The dropper will only drop one ball at a time.

Warning!

- When using the launcher, be careful not to use it close to your face.
- Be careful not to hit your eyes or face.
- Be careful when using this product around children or the elderly.
- Do not look inside the launcher when putting the ball in.
- The noise will be loud when the ball is launched.
- Do not use or keep your product near water sources.

7. Receiver LED Indicator Light



When you press the corresponding button on the transmitter for the designated receiver, the LED indicator light on the transmitter and receiver will both light up momentarily. When the receiver is turned on, the LED indicator light will blink every 5 seconds.

Checking the Battery Life

The LED indicator color indicates the battery life level.

Green = Battery full charge

Amber = Battery medium charge

Red = Battery needs to be replaced

If the unit is used while the LED indicator is red, it may shut down automatically.

8. Replacing the Receiver Battery

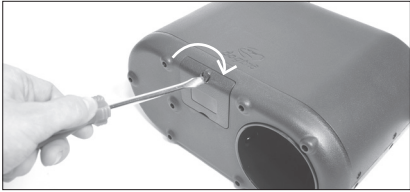

1. Using a screwdriver or coin, loosen the screw on the battery cover at the bottom of the receiver.

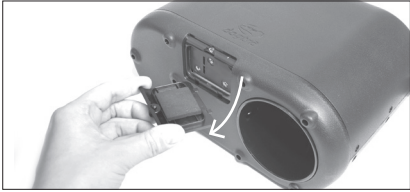

2. Carefully take out the battery holder and replace the batteries in the holder with six AA 1.5V alkaline batteries.

Check that the batteries match the polarity indicated on the battery holder.



It may be difficult to replace the battery since the cover is tightly in place. Be careful when taking off the battery cover.

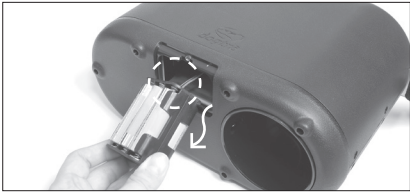

Caution!

Please make sure you do not forcefully pull out the battery holder. The wire connected to the battery holder may break.



3. Before closing the battery cover, please make sure that the battery holder is properly placed into the battery compartment. Place the battery cover over the battery compartment and use a screwdriver or coin to tighten the screw back on.



Caution!

If you tighten the screws too much, it will strip the screws and spin.

9. Transmitter LED Indicator Light



When you press the corresponding button on the transmitter for the designated receiver, the LED indicator light on the transmitter and receiver will both light up momentarily.

Checking the Battery Life

The LED indicator color indicates the battery life level.

Green light when pressed = Battery full charge

Green light blinks on its own = Battery needs to be replaced

If the unit is used while the LED indicator light blinks green, it may shut down automatically.

10. Replacing the Transmitter Battery

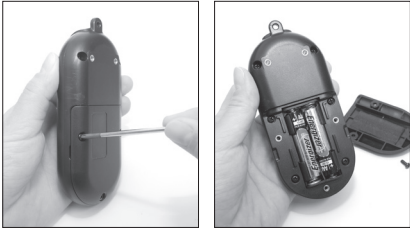

1. Using a screwdriver, remove the 3 screws on the battery cover on the back of the transmitter.



2. Replace the batteries with two AAA 1.5V alkaline batteries. Check that the batteries match the polarity indicated on the battery holder.



3. Place the battery cover back into place and use a screwdriver to tighten the screws back on.

Caution!

If you tighten the screws too much, it will strip the screws and spin.

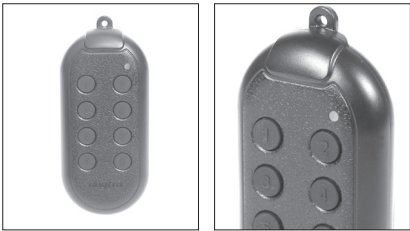

4. To make sure that the transmitter is working properly, press one of the buttons to see if the LED indicator light shows up green.

11. Using the Battery Correctly

- 1) When inserting the batteries into the unit, make sure the battery matches the positive or negative polarity.
- 2) Please remove the batteries from the device if it will not be used or placed in storage for a long time.
- 3) If you are storing the batteries, do not store it together with metal products.
- 4) If the battery expires, replace the battery with a new one even if it has some capacity left.

12. Maximizing the Distance

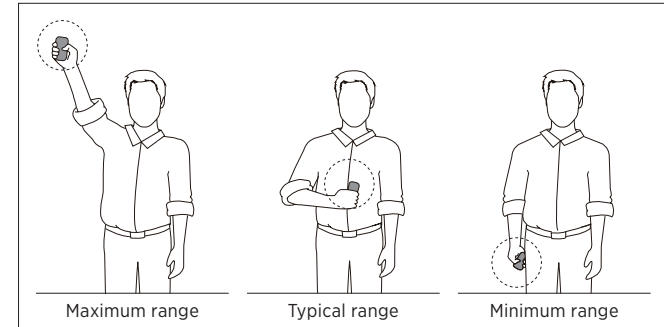

The range for the BALL TRAINER is 100 yards, which can vary depending on the way you use your transmitter. It may also vary depending on geographical conditions and the surrounding environment.

To get the greatest range, follow the instructions below.

- To improve the range, hold the transmitter in your hand and do not block the top of the transmitter (there is an internal antenna).
- Get the best range when holding the transmitter away from your body and placing it above your head.
- Always check the batteries in your transmitter and receiver before usage and replace the batteries if necessary.
- The battery performance will decline when used in colder temperatures (below 32°F).

13. Code Setting

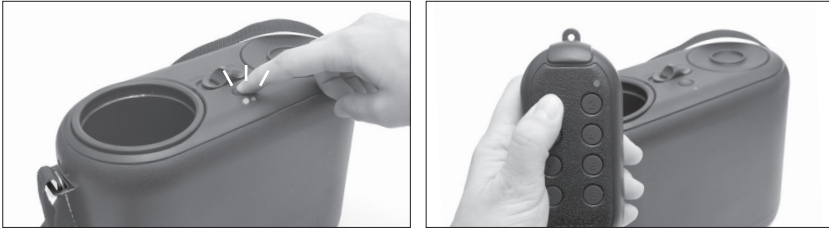

The transmitter has a code for each button. In order to add another receiver, you will need to code the new receiver to the transmitter.

- 1) Make sure that the receiver is off.
- 2) Press and hold down the on/off button on top of the receiver for 5 seconds.
- 3) The LED indicator light will rapidly blink green. You can release your finger from the button.
- 4) Press the number on the transmitter that you would like to code the receiver to. You may check that it is properly coded by pressing the button on the transmitter, which will activate the LED indicator light on the receiver at the same time.

*** You can code up to eight receivers to one transmitter**

Warning!

Do not use any other transmitter before programming a new receiver. The receiver can accidentally code to another transmitter if used at the same time. If this happens, you will need to recode the receiver to the correct transmitter.

14. Attaching the Belt Clip

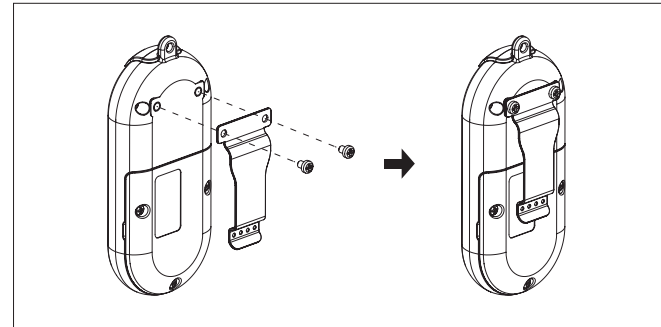

Follow the instructions below to attach the included belt clip to the transmitter.

1. Align the belt clip to the grooves on the back of the transmitter.
2. With a firm grip, screw on the belt clip's Phillips head screws with a screwdriver.

Caution!

Tighten until firmly in place. Be careful not to over tighten.

GENERAL TRAINING TIPS

Getting Started With Your BALL TRAINER

Your dog must know some basic obedience commands before beginning training with the BALL TRAINER. A dog learns by first being shown a command, followed by lots of repetition over an extended period. As the dog becomes proficient at these commands, the trainer can introduce distractions and different locations to strengthen them.

For more training information, please visit our website at www.dogtra.com.

MAINTENANCE

Basic Maintenance

After each training session, carefully inspect the unit for any missing parts or damage to the casing. Damaged or broken casing may affect the unit. After confirming that there is no damage to the casing, clean off any dirt or debris.

Storage Maintenance

The BALL TRAINER battery should be taken out before storing the unit for extended periods of time. Store the units in room temperature. Do not keep the units exposed to extreme climates.

Troubleshooting

If the unit is malfunctioning, please refer to the “Troubleshooting Guide” before sending it to Dogtra for service. If you have any questions or concerns, you may email them to info@dogtra.com, or call customer service at 1-888-811-9111.

FCC WARNING

The BALL TRAINER complies with part 15 of the FCC Rules. Operation is subject to the following two conditions:

- (1) This device may not cause harmful interference, and
- (2) This device must accept any interference received, including interference that may cause undesired operation.

This is a sensitive radio device. Any unauthorized changes or modifications to this device that are not expressly approved by Dogtra will void the warranty, and may void the user's authority to operate the equipment.

Please do not tamper or modify the unit.

TROUBLESHOOTING GUIDE

1. The transmitter has no range or the BALL TRAINER does not launch when the dog is farther away.
 - The range indicated on the unit's box is for flat terrain. Heavy brush, trees, hills, or moisture may affect the range of your unit. For the best range, hold the transmitter vertically above your head, and/or try moving to higher ground.
 - Any electrical conductors may affect the range, such as cars, metal structures, and radio towers. For best results, operate the BALL TRAINER away from these items.
 - Do not put the transmitter in your pocket as it will shorten the range by blocking the signal to the receiver.
2. When do I need to replace the batteries in the BALL TRAINER?
 - If the unit is not activating or the LED indicator light does not turn on, the batteries may need to be replaced. The overall battery life will depend on the usage.
 - The LED indicator light will go from green to amber to red. When the LED indicator light shows red, the batteries need to be replaced.
3. How do I clean the BALL TRAINER?
 - To clean the BALL TRAINER, make sure that the battery covers are closed and fully sealed. Wipe down the unit with a damp cloth. Make sure the unit is completely dry before use.
4. Why types of balls can I use with the system?
 - You may use Dogtra' authorized balls, tennis balls, or balls with similar texture and size (diameter of 2.6 inches or 6.6 cm).
5. Why does the BALL TRAINER turn off automatically?
 - The BALL TRAINER receiver automatically turns off after 3 hours of non-use to conserve battery power. To turn the BALL TRAINER receiver on again, press the on/off button.
 - Check the LED indicator light. If the LED indicator is red, replace the batteries in the BALL TRAINER (see above).
 - If the above does not resolve your issues, contact Dogtra customer service at info@dogtra.com or 888-811-9111.

WARRANTY AND REPAIR INFORMATION

1-Year Comprehensive Warranty

Dogtra Company provides the original purchaser with a 1-Year Comprehensive Warranty for the iQ Pet Series, EF-3000 GOLD, E-FENCE 3500, RR DELUXE, YS200, YS300, YS500, YS600, and the BALL TRAINER. The warranty begins from the date of purchase. For the first year, coverage is for parts, labor, and accessories. After the first year, the cost of parts, accessories, labor fees, and shipping fees incurred are the customer's responsibility. Labor fees will be variable depending on the extent of the work required.

To Qualify for the Dogtra Warranty

All products must be registered and/or a proof of purchase is required to initiate repair work under warranty. To register your Dogtra product, log onto our website at www.dogtra.com, click on the warranty registration link, and fill out the required information. Registration must be completed within 30 days of purchase. If you do not have access to a computer, you can call our toll free number at 1-888-811-9111, and one of our customer service representatives will register the product for you. If you were unable to register your product within 30 days of purchase, we will accept all products for repair with a proof of purchase. We strongly recommend keeping the original receipt. If your product is not registered and a proof of purchase is not available at the time of service, Dogtra will estimate the age of the unit by the serial number. Serial number estimates can differ from the actual purchase date. A serial number estimate is the only method of determining an approximate date of purchase without product registration or a proof of purchase.

Not Covered Under Warranty

Dogtra DOES NOT offer warranty for products that have been bought secondhand or as a resold product. Dogtra DOES NOT replace defective units or provide refunds for products purchased from us after 30 days from the date of purchase. Dogtra DOES NOT cover the cost of shipping outside of the Continental United States. Issues of replacement and refunds on units purchased less than 30 days from an authorized dealer must be addressed to the dealer directly. If the products purchased from an authorized dealer are after 30 days from the date of purchase, please send the units to Dogtra for service and repair. Dogtra DOES NOT cover the cost of repairs and replacements due to misuse by the owner or dog, improper maintenance, and/or lost units. Any water damage on the water resistant transmitters of the 175NCP, 180NCP, 200NCP Series, 1400NCP Series, 1500NCP Series, iQ Pet Series, and BALL TRAINER, and the water resistant receivers of the RRS, RRD, RR DELUXE, and BALL TRAINER will not be covered. All replacement costs for either the transmitter or receiver will be the owner's responsibility. The warranty is void if the unit has been altered or an unauthorized person has damaged the unit while attempting repair work. Battery replacement by the customer during the first year of the 1-Year Comprehensive Warranty is not recommended. If the customer chooses to replace the batteries, any damage to the unit during the change-out by the owner will void the warranty. The removal of serial numbers from any Dogtra products will void the warranty. Dogtra reserves the right to retain and discard any parts or accessories that have been found damaged upon replacement and repair.

Procedure for Repair Work

If the unit is malfunctioning, please refer to the "Troubleshooting Guide" in the Owner's Manual and call customer service at 1-888-811-9111 for technical support, before sending it to Dogtra for service. The cost of shipping products under warranty back to Dogtra is the customer's responsibility. Dogtra is not responsible for units damaged or lost in transit to Dogtra. Dogtra is not responsible for loss of training time or inconvenience while the unit is in for repair work. Dogtra does not provide loaner units or any form of compensation during the repair period. A copy of the sales receipt showing the purchase date may be required before warranty work is initiated. Please include a brief explanation outlining the problem and include your name, address, city/state/zip code, daytime phone number, evening phone number, and email address. Or you can visit our website at www.dogtra.com for a service request form. If the repair costs are not covered under warranty, we will call you for payment information and authorization. For any questions concerning your Dogtra products, call us toll free at 1-888-811-9111, M-F 8:30AM - 4:30PM, Pacific Standard Time, or email us at repair@dogtra.com for specific repair inquiries.

Send repair units to Dogtra Company / Repairs 22912 Lockness Avenue, Torrance, CA 90501, U.S.A.

The diagrams and representations in the manual may differ slightly from the actual product depending on the model type.